

PL **INSTRUKCJA**
Pawilon ogrodowy z zasłonami

EN **INSTRUCTIONS**
Garden pavilion with curtains

3x4 m



PL: Zachowaj instrukcję do późniejszego użycia. / EN: Keep the manual for future reference.

NR PARTII/BATCH NO.: WZ5-A-0006C

Producent:
4iQ Group sp. zo.o.
ul. L. Mierosławskiego 6, 14-200 Łława
kontakt@4iQ.com.pl
tel. +48 89 674 92 57
www.4iQ.com.pl





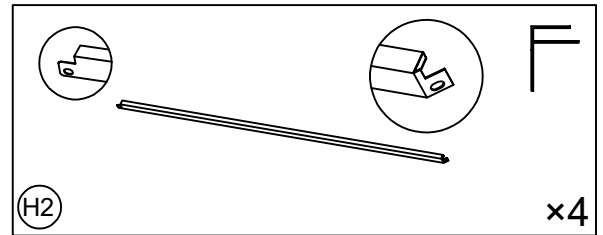
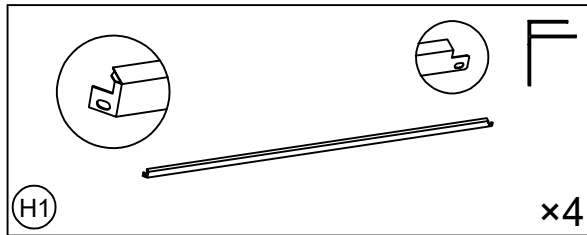
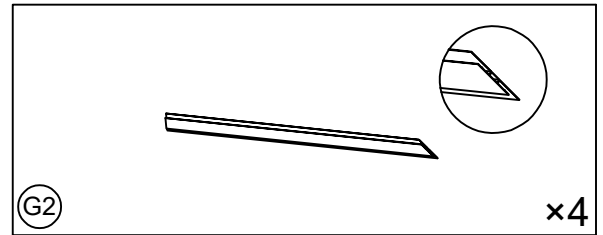
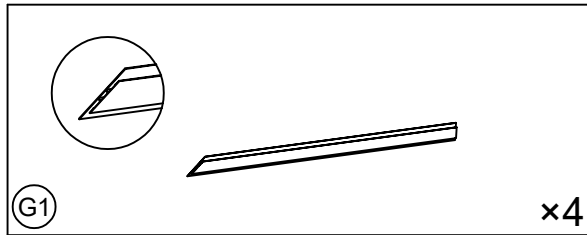
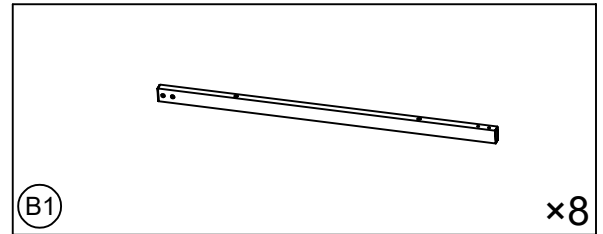
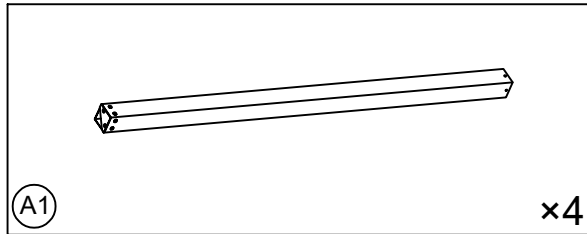



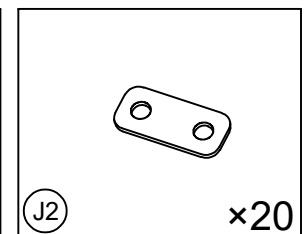
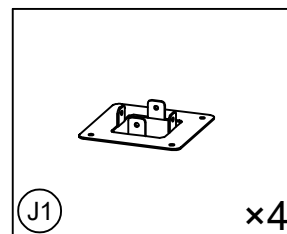
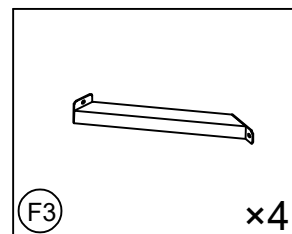
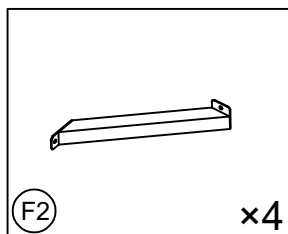
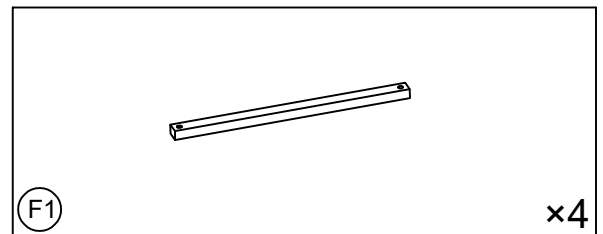
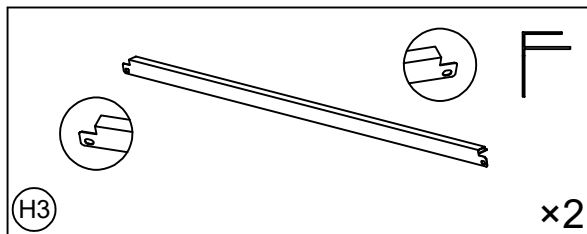
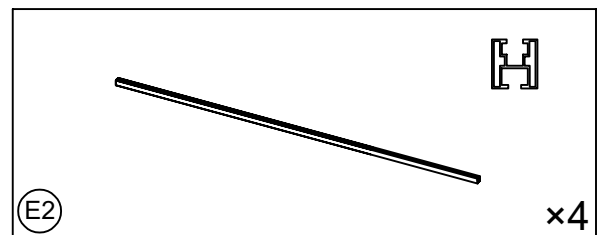
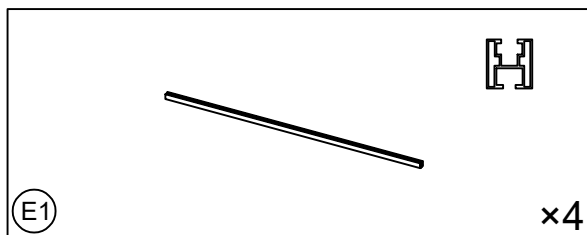
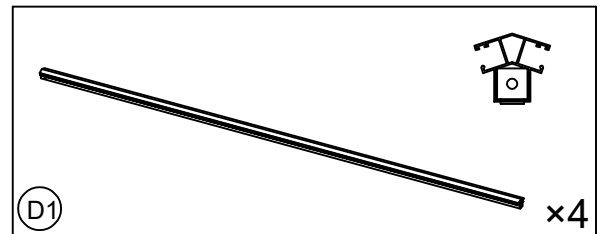
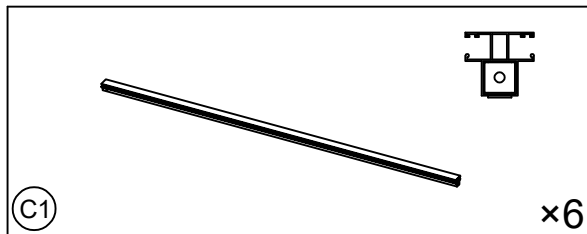
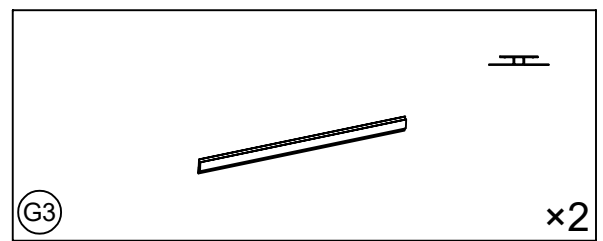
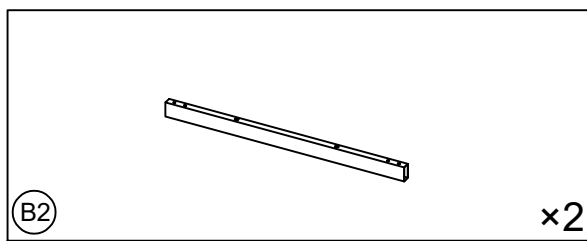



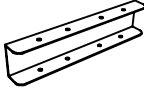

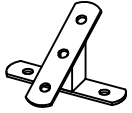
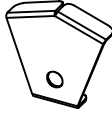
KARTON / BOX
1/3

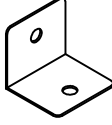
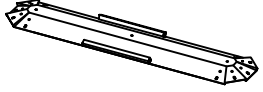

KARTON / BOX
2/3



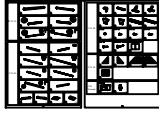

KARTON / BOX
2/3

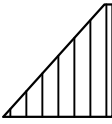
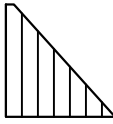
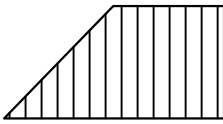
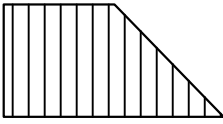
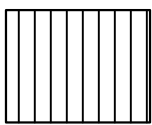

| | | | |
|--|--|---|--|
|  (J3) x8 |  (J4) x6 |  (J5) x4 |  (J6) x6 |
|  (J7) x4 |  (J8) x6 |  (J9) x4 |  (J10) x1 |
|  (J11) x1 | M6 Nut  (K1) x28 | M6 x 10  (K2) x28 | M6 x 15  (K3) x150 |
| M6 x 25  (K4) x11 | M6 x 45  (K5) x16 | 4mm Allen wrench Klucz imbusowy 4mm  (T1) x1 | Installation manual Instrukcja montażu  (T2) x1 |

KARTON / BOX
3/3

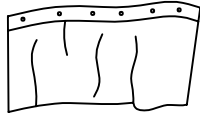
| | | | |
|--|--|---|--|
|  (L1) x4 |  (R1) x4 |  (L2) x4 |  (R2) x4 |
|  (M1) x4 | | | |



Ściany boczne
Sidewalls

| | |
|--|---|
|  (S1) x4 |  (S2) x56 |
|--|---|

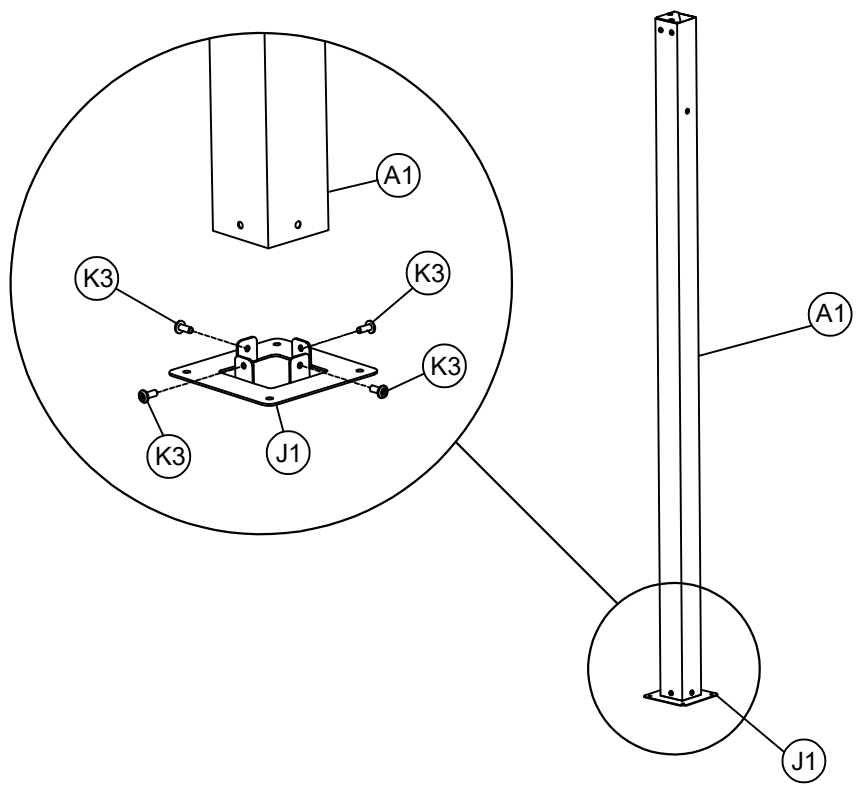
-  (A1) ×4
-  (J1) ×4
- M6 × 15
-  (K3) ×16



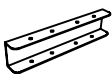

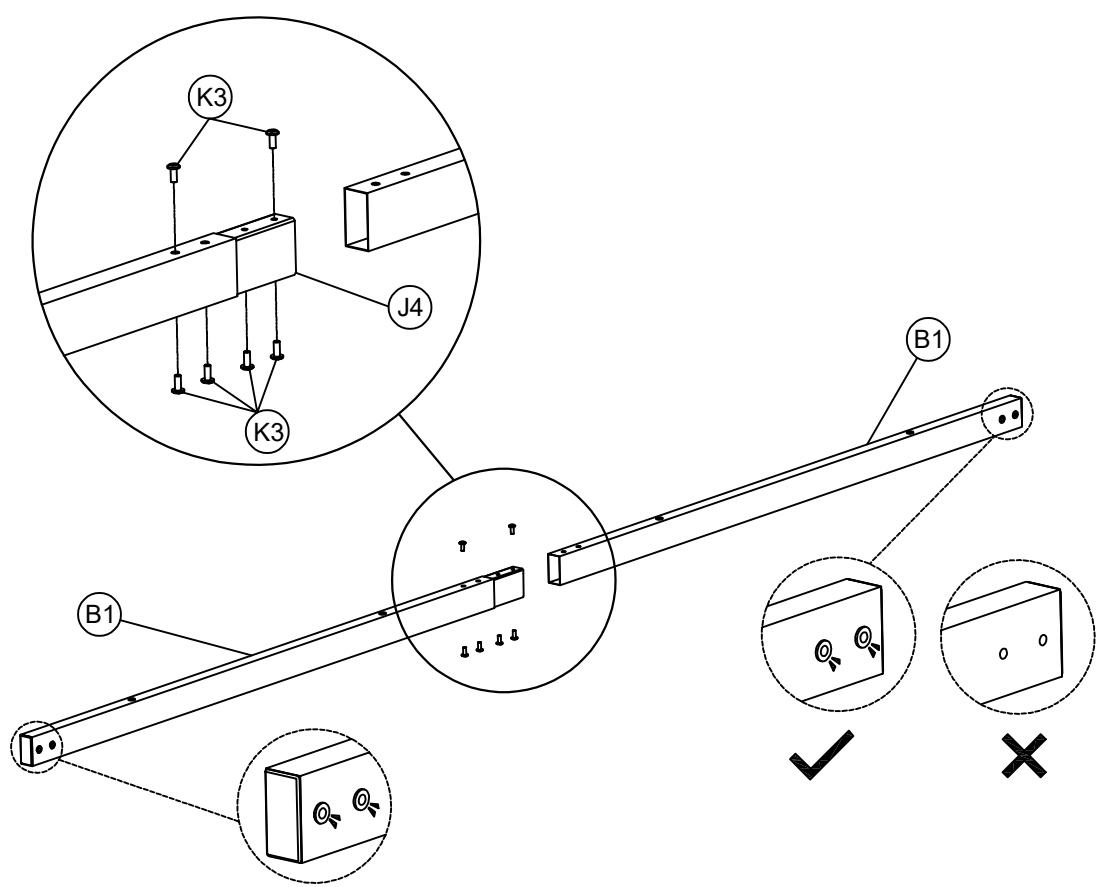

×4

-  (B1) ×4
-  (J4) ×2
- M6 × 15
-  (K3) ×12

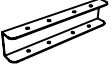

×2

| | | |
|---|-----------|------------|
|  | B1 | ×4 |
|  | B2 | ×2 |
|  | J4 | ×4 |
| M6 × 15 | | |
|  | K3 | ×24 |

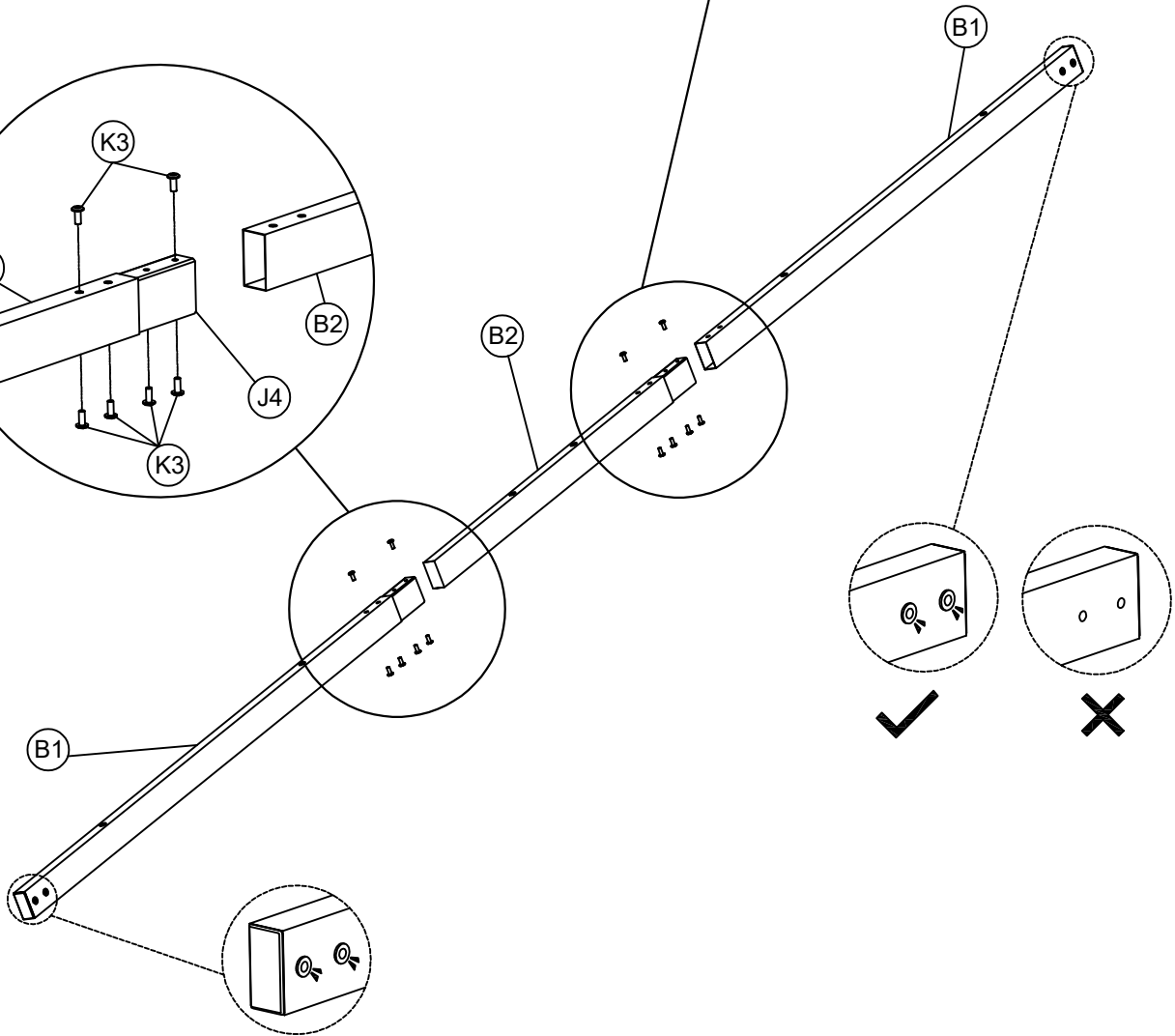
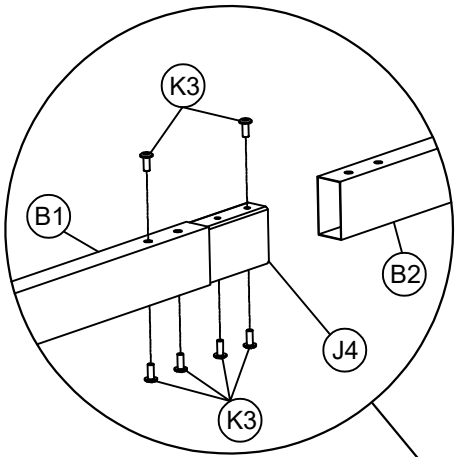
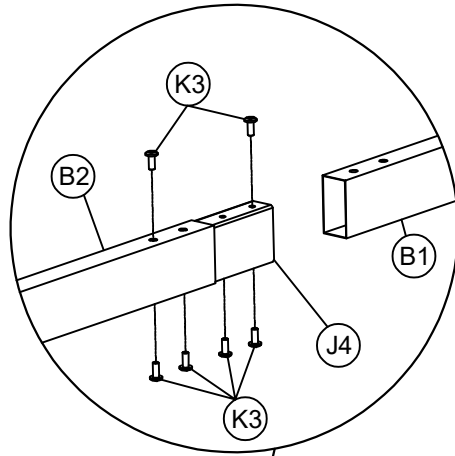

M6 x45







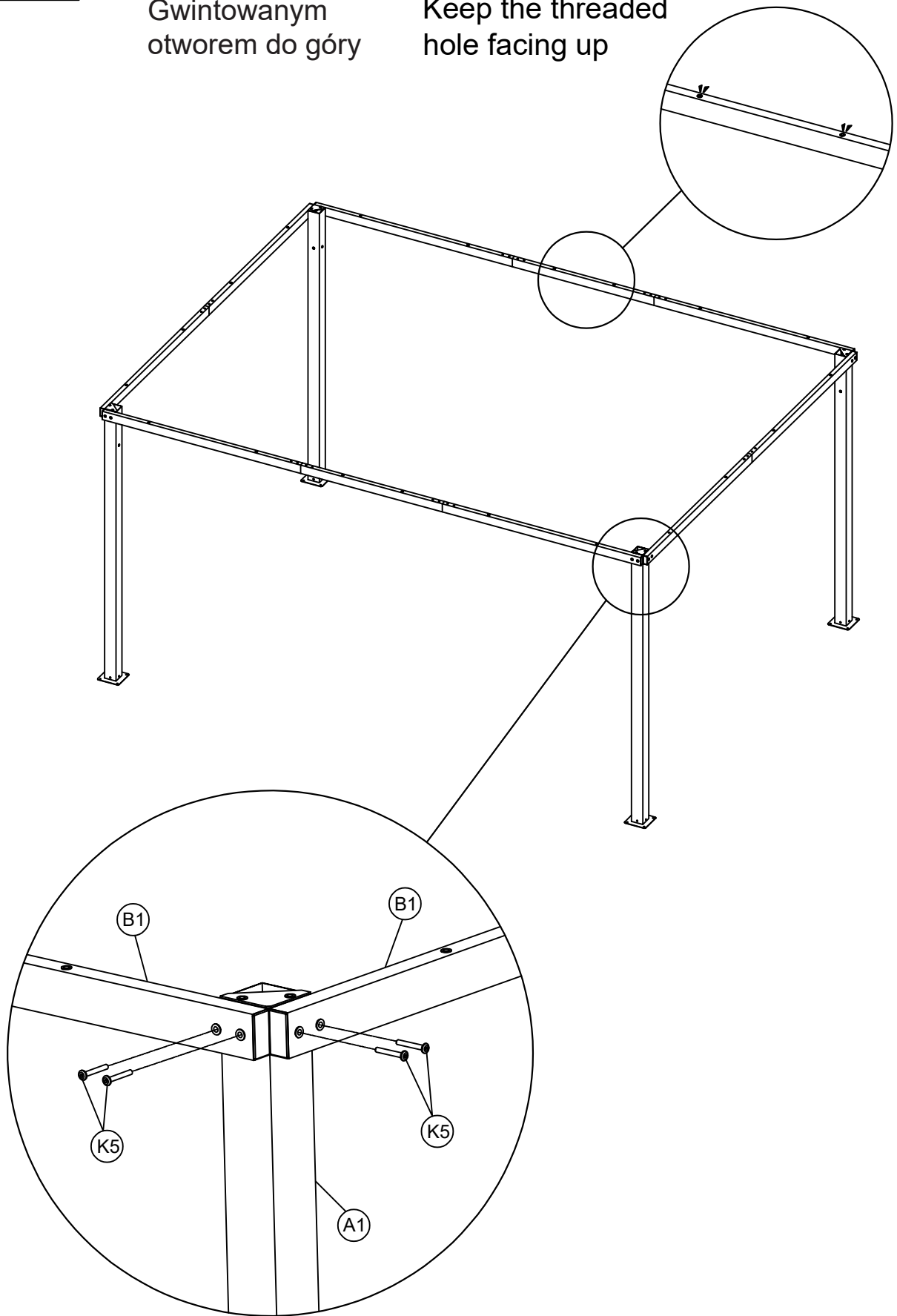

(K5)

x16







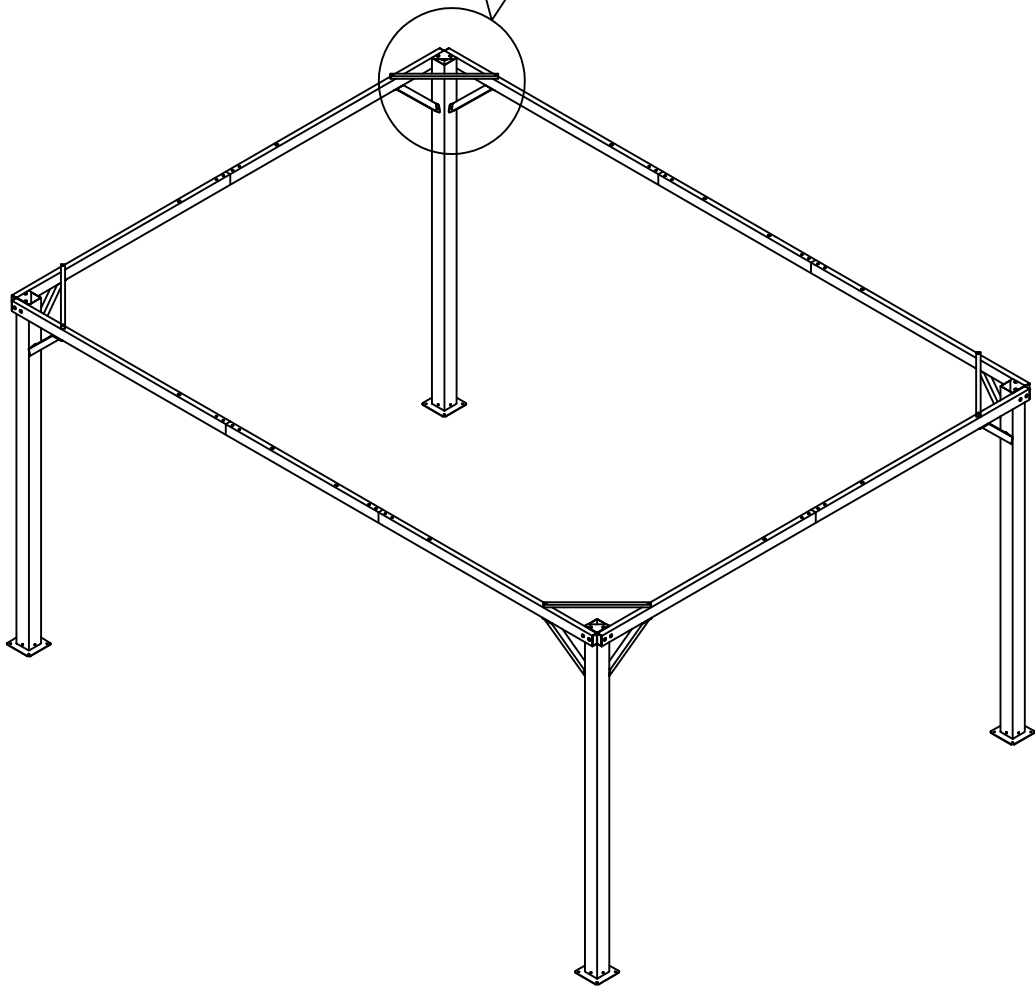
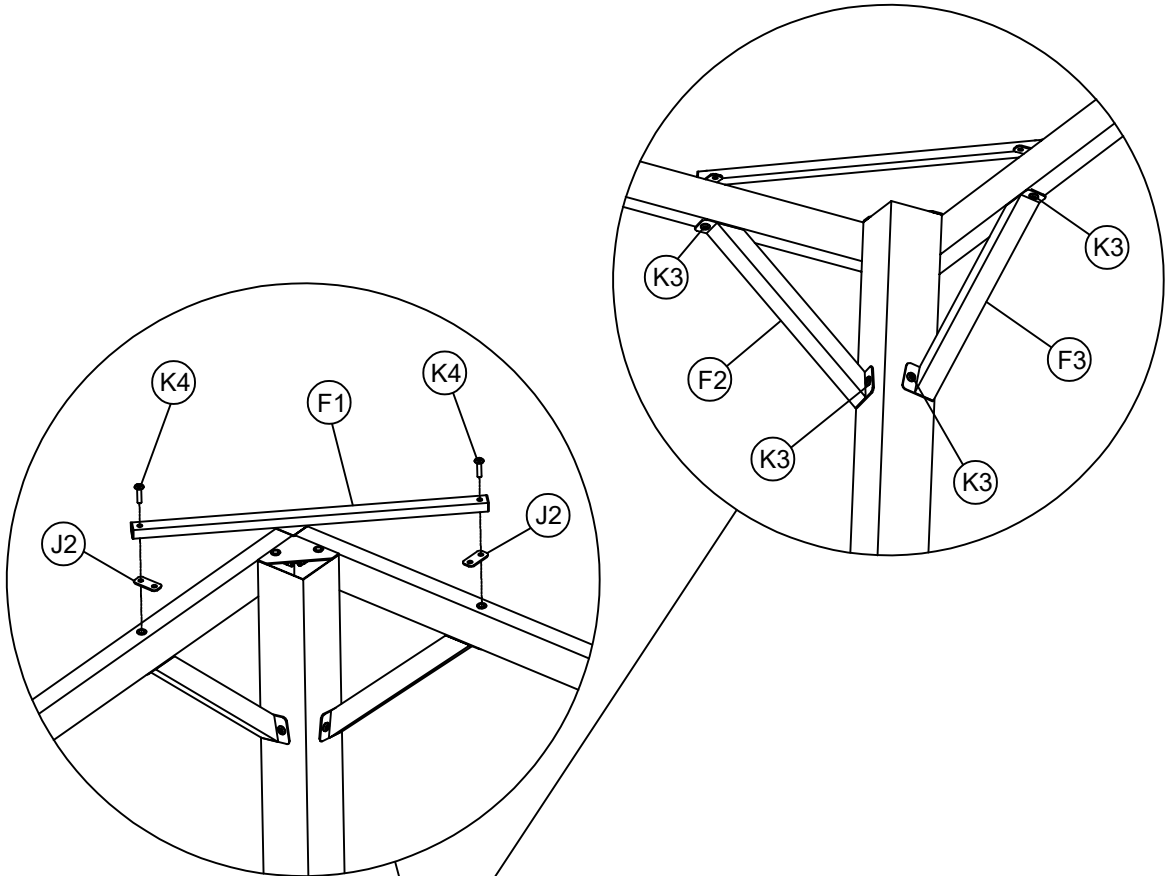

Gwintowanym
otworem do góry

Keep the threaded
hole facing up







| | | |
|---------|---|-----|
| (F1) |  | ×4 |
| (F2) |  | ×4 |
| (F3) |  | ×4 |
| (J2) |  | ×8 |
| M6 × 15 |  | ×16 |
| (K3) |  | ×8 |

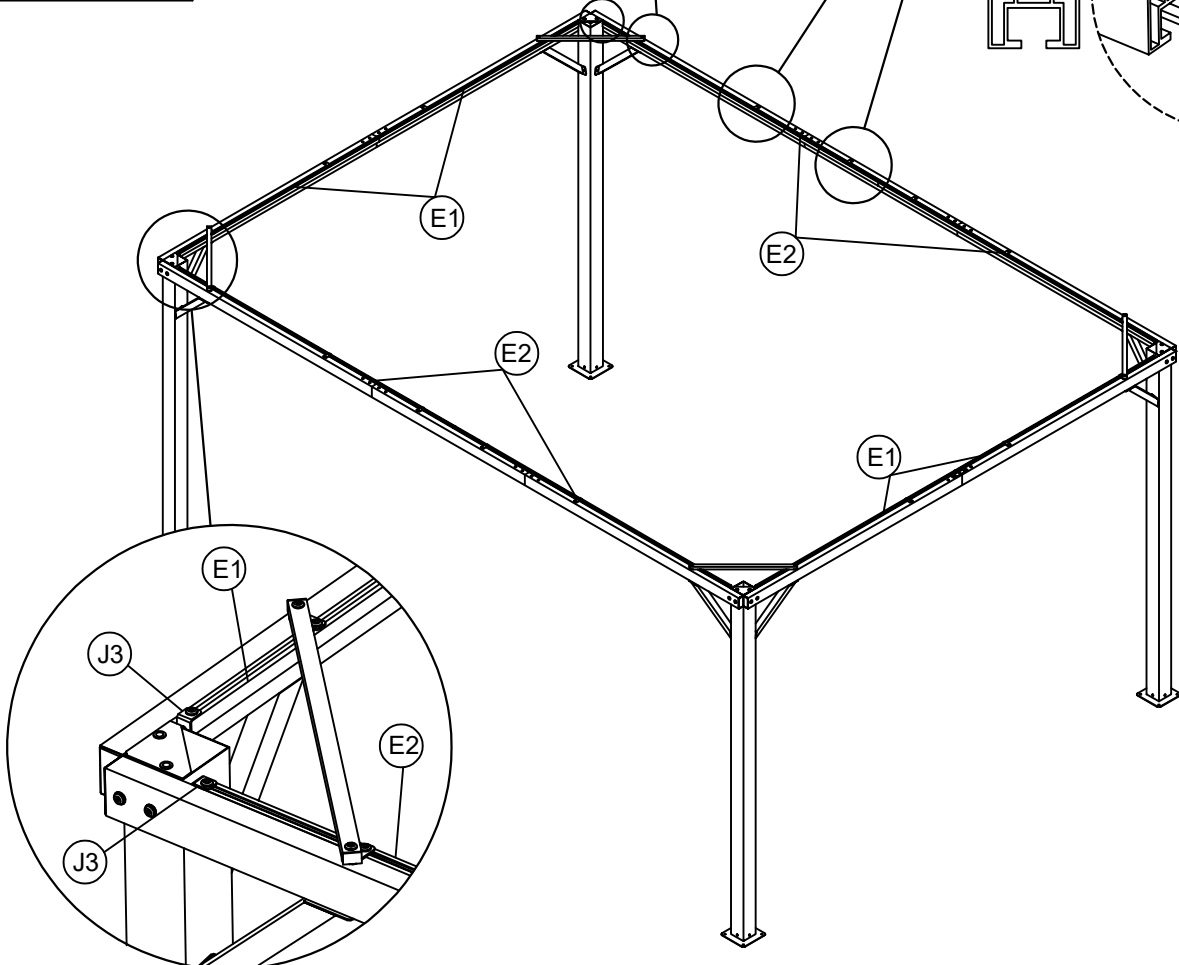
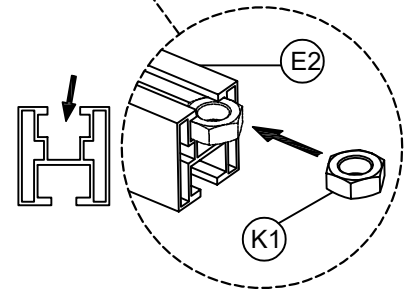
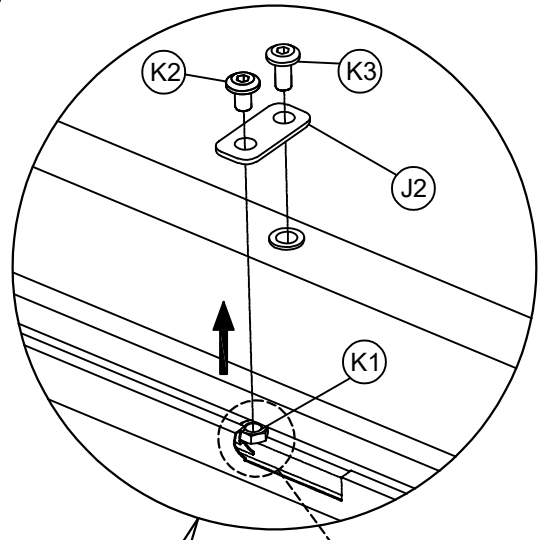
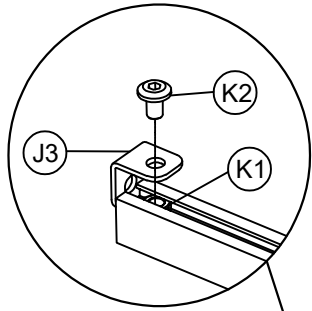
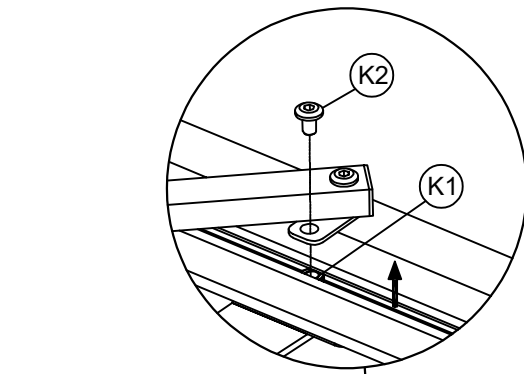

| | | |
|--|---|-----|
|  |  | x4 |
|  |  | x4 |
|  | | x12 |
|  | | x8 |
| M6 Nut | | |
|  | | x28 |
| M6 x 10 | | |
|  | | x28 |
| M6 x 15 | | |
|  | | x12 |

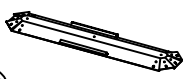

-   x4
-  x1
-  x4
- M6 x 15
-  x16

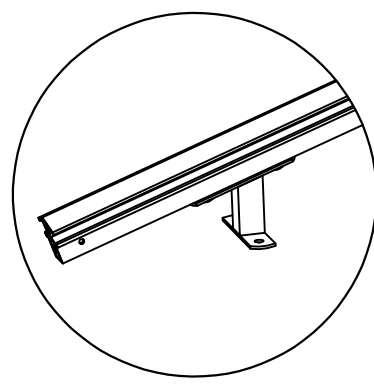
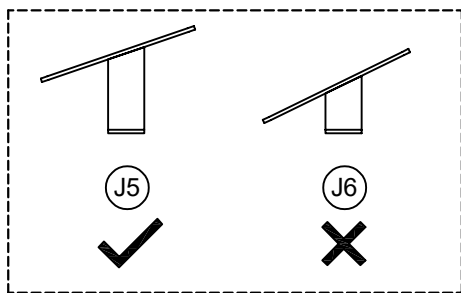
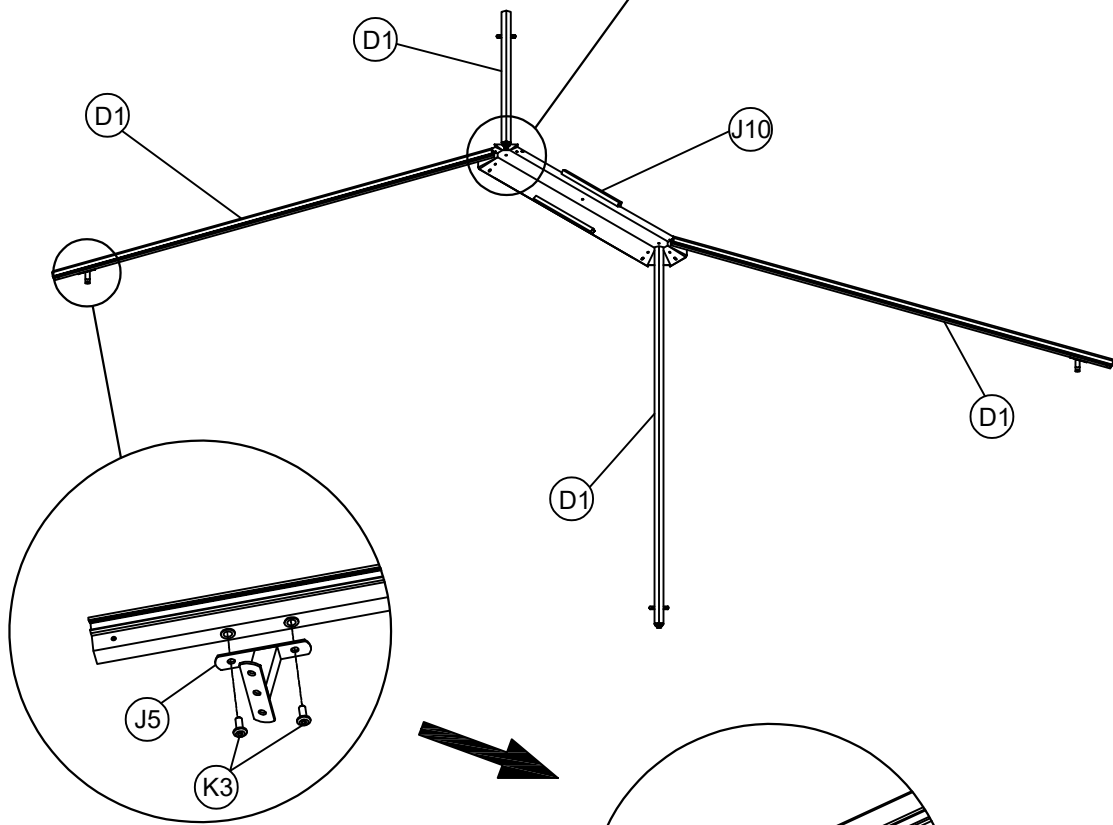
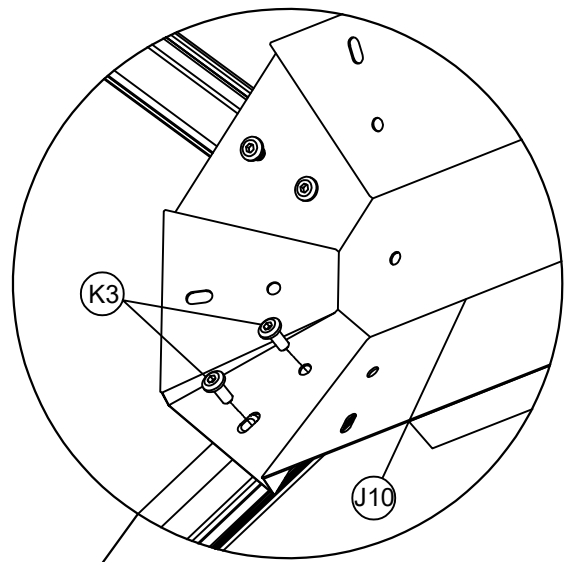





M6 × 15



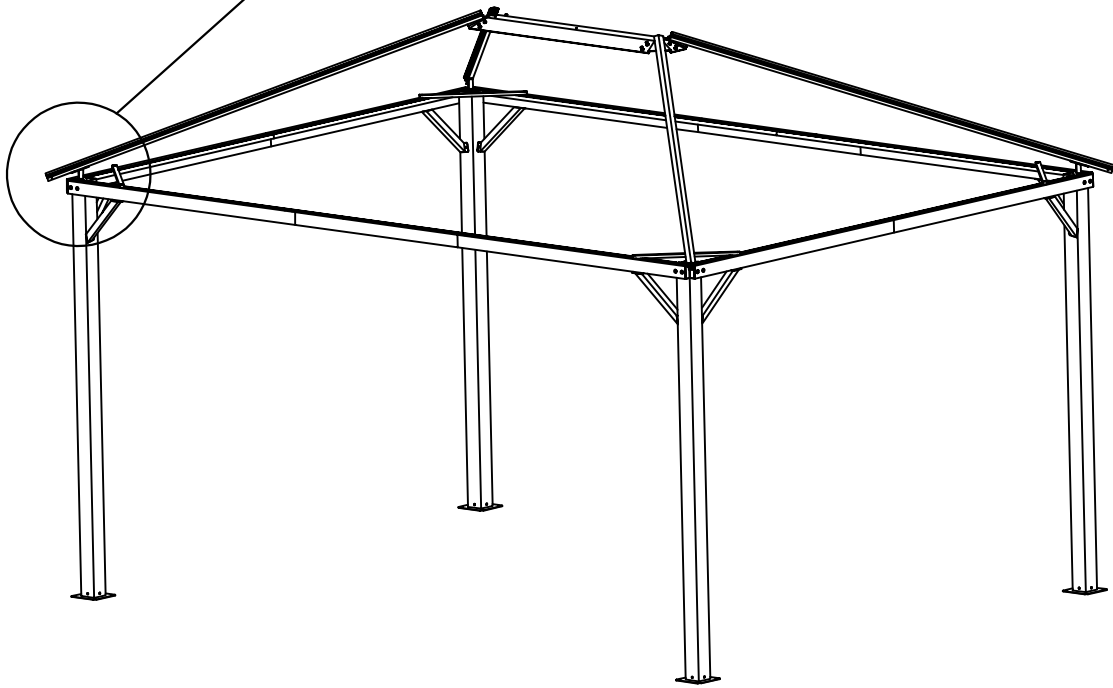
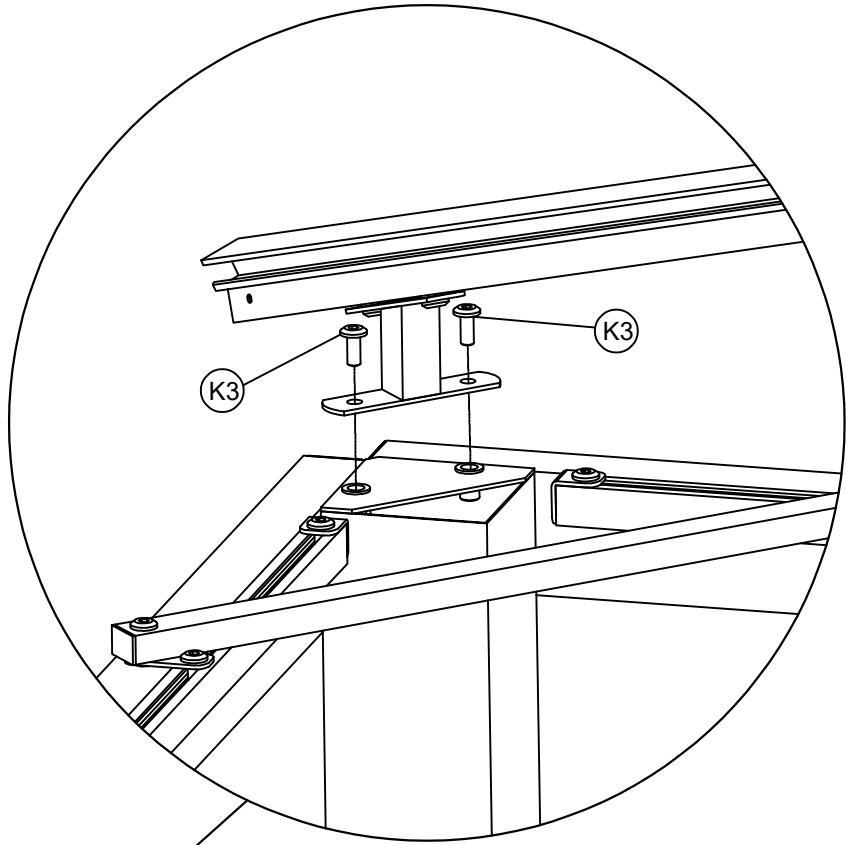

K3

×8

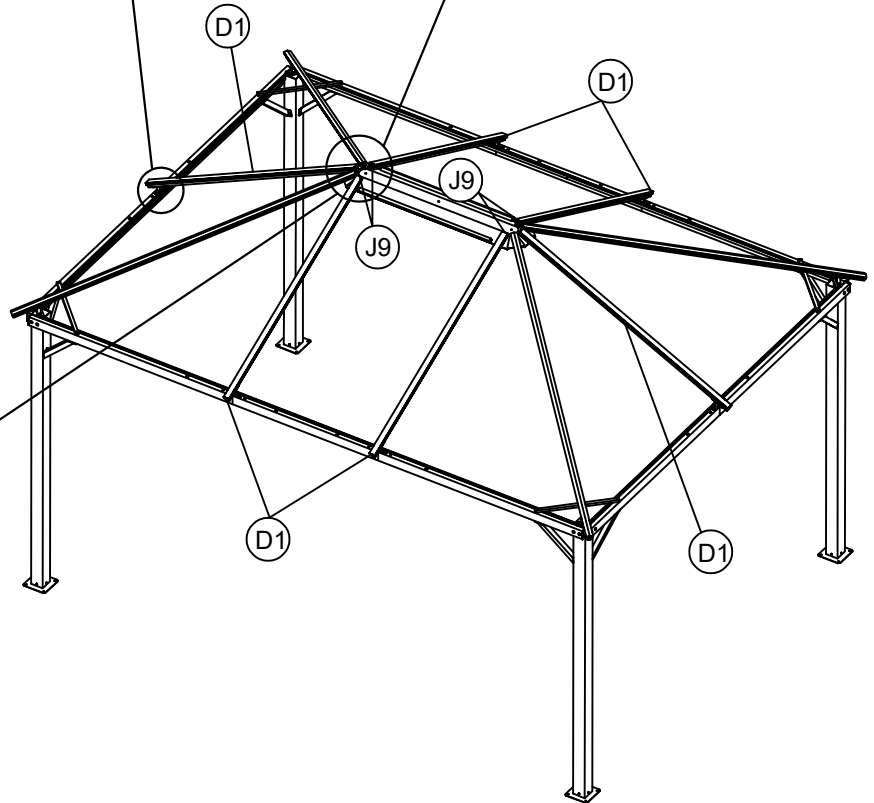
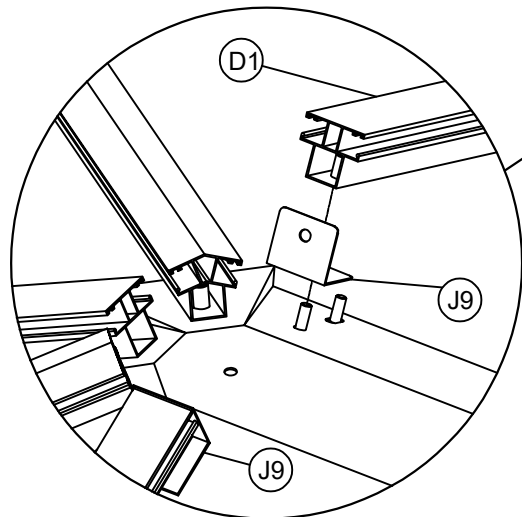
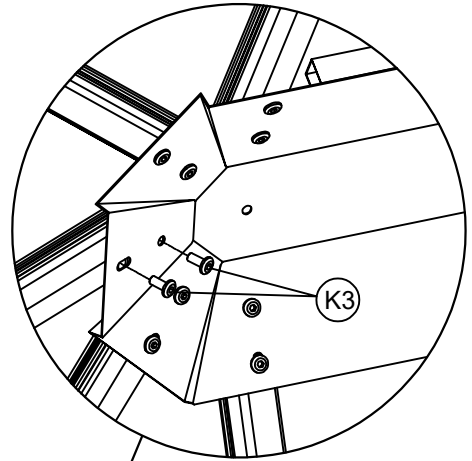
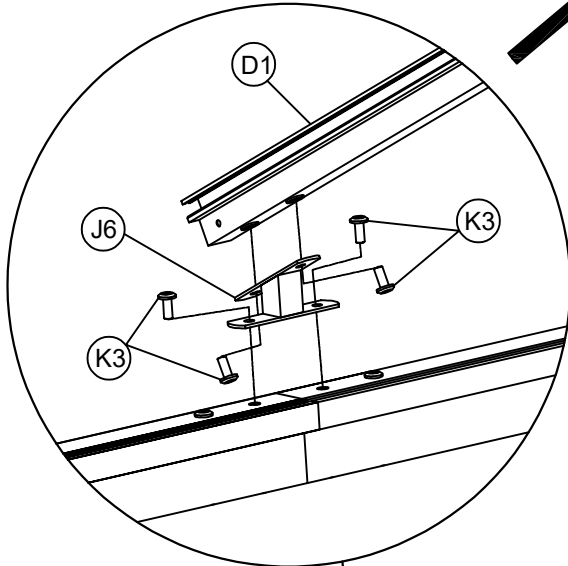
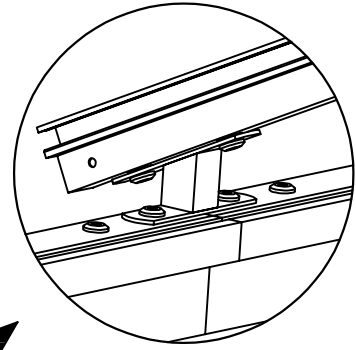
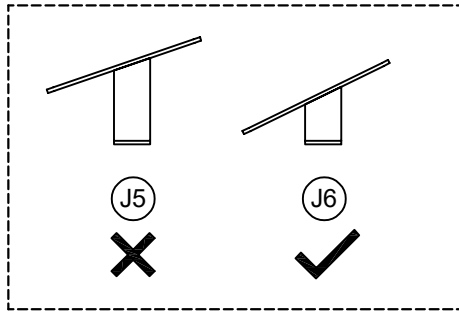

| | | |
|---------|---|-----|
| (D1) |  | ×6 |
| (J6) |  | ×6 |
| (J9) |  | ×4 |
| M6 × 15 | | |
| (K3) |  | ×36 |



| | |
|---|----|
|  | x1 |
| M6 x 25 | |
|  | x3 |

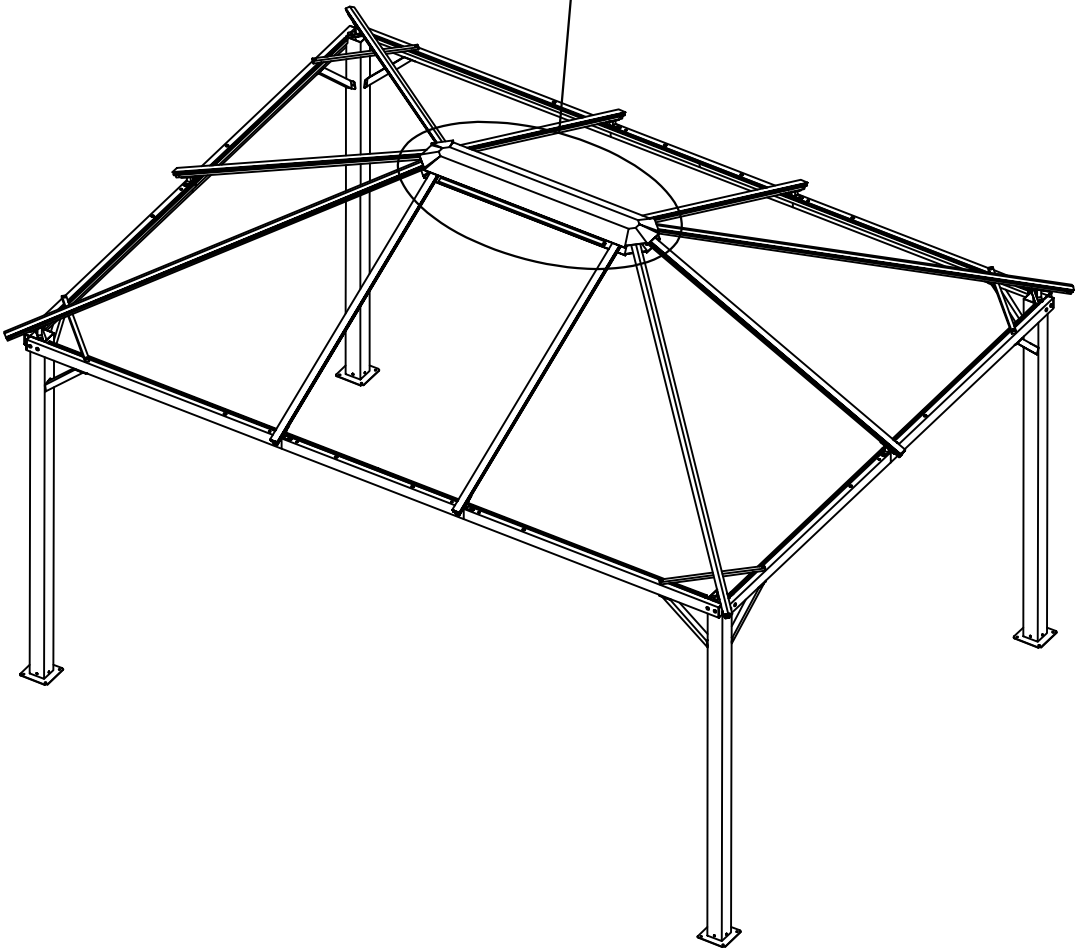
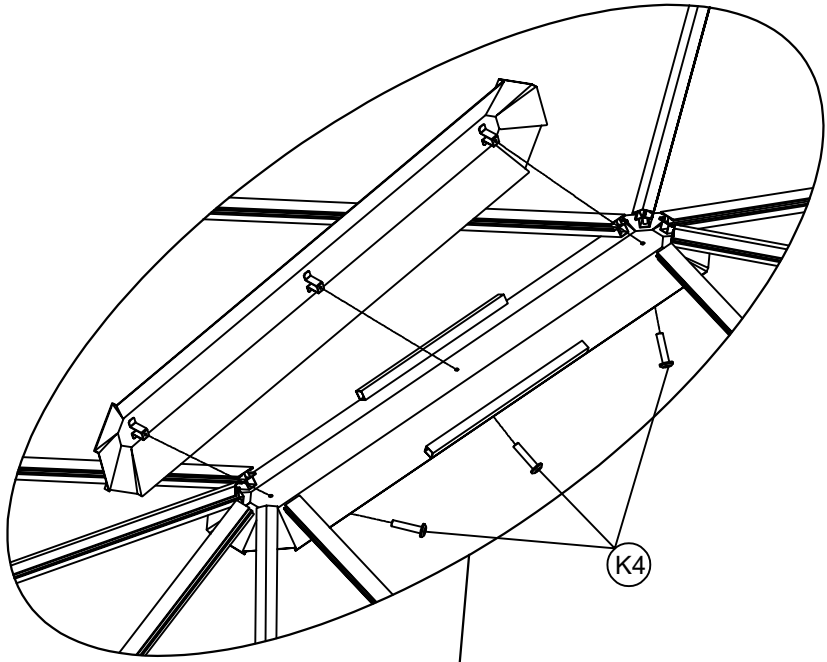

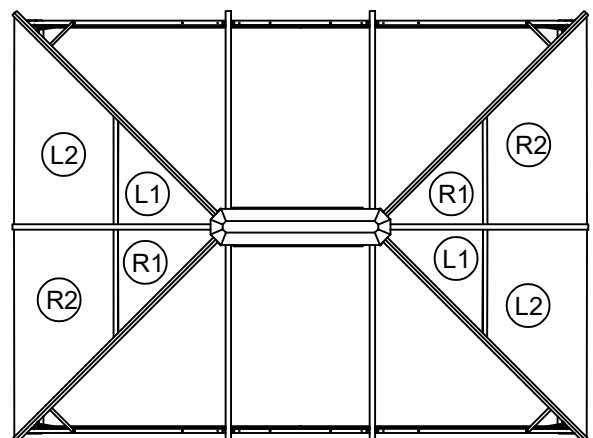
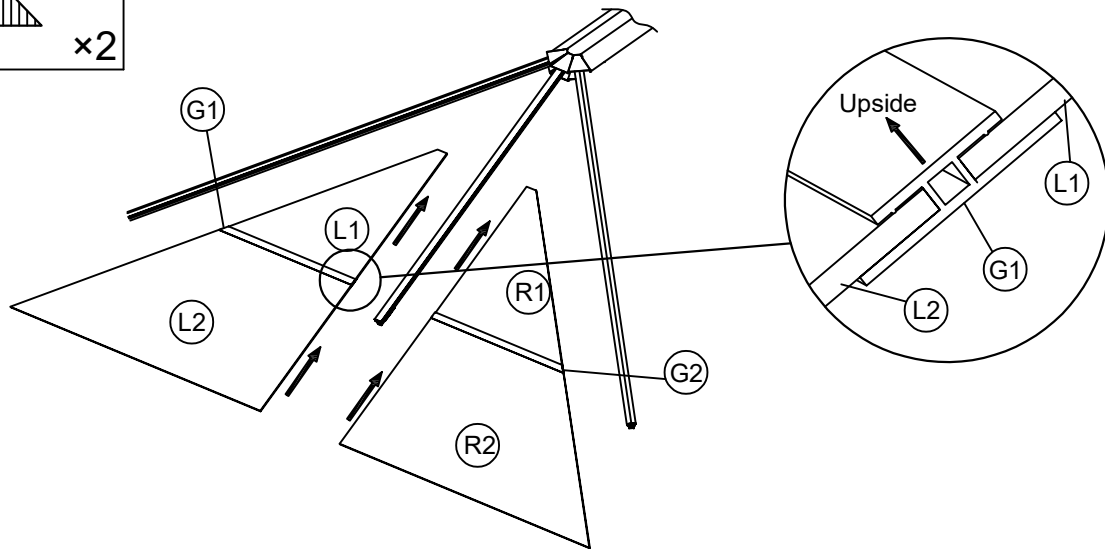
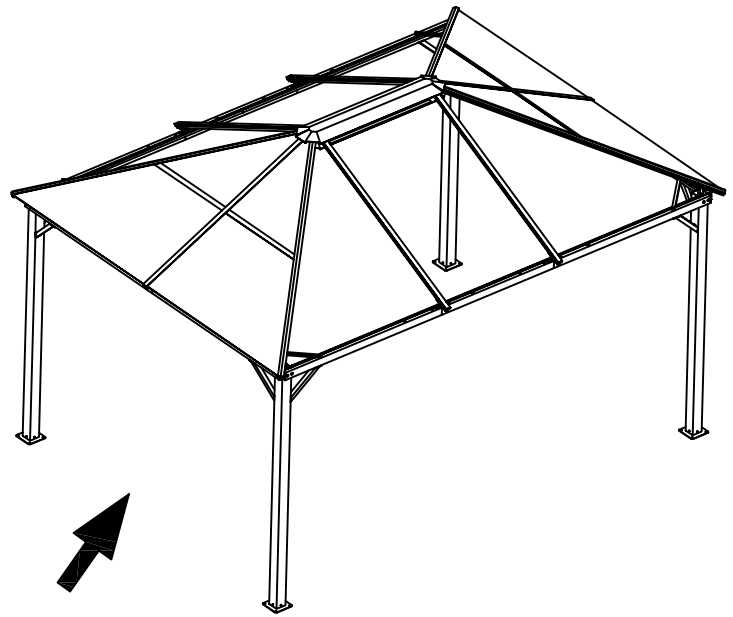
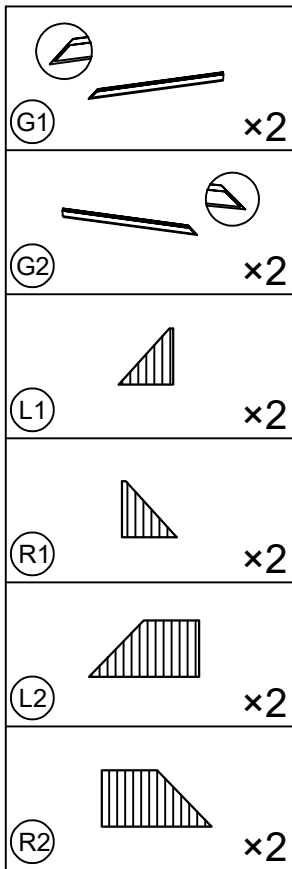

Uwaga:

1. Zdejmij folie ochronną przed instalacją.
2. Montować stroną pokrytą **transparentną folią ochronną do góry.**

Notice:

1. Remove the protective film before installation.
2. The side covered with the **transparent protective film must face the sunlight!**

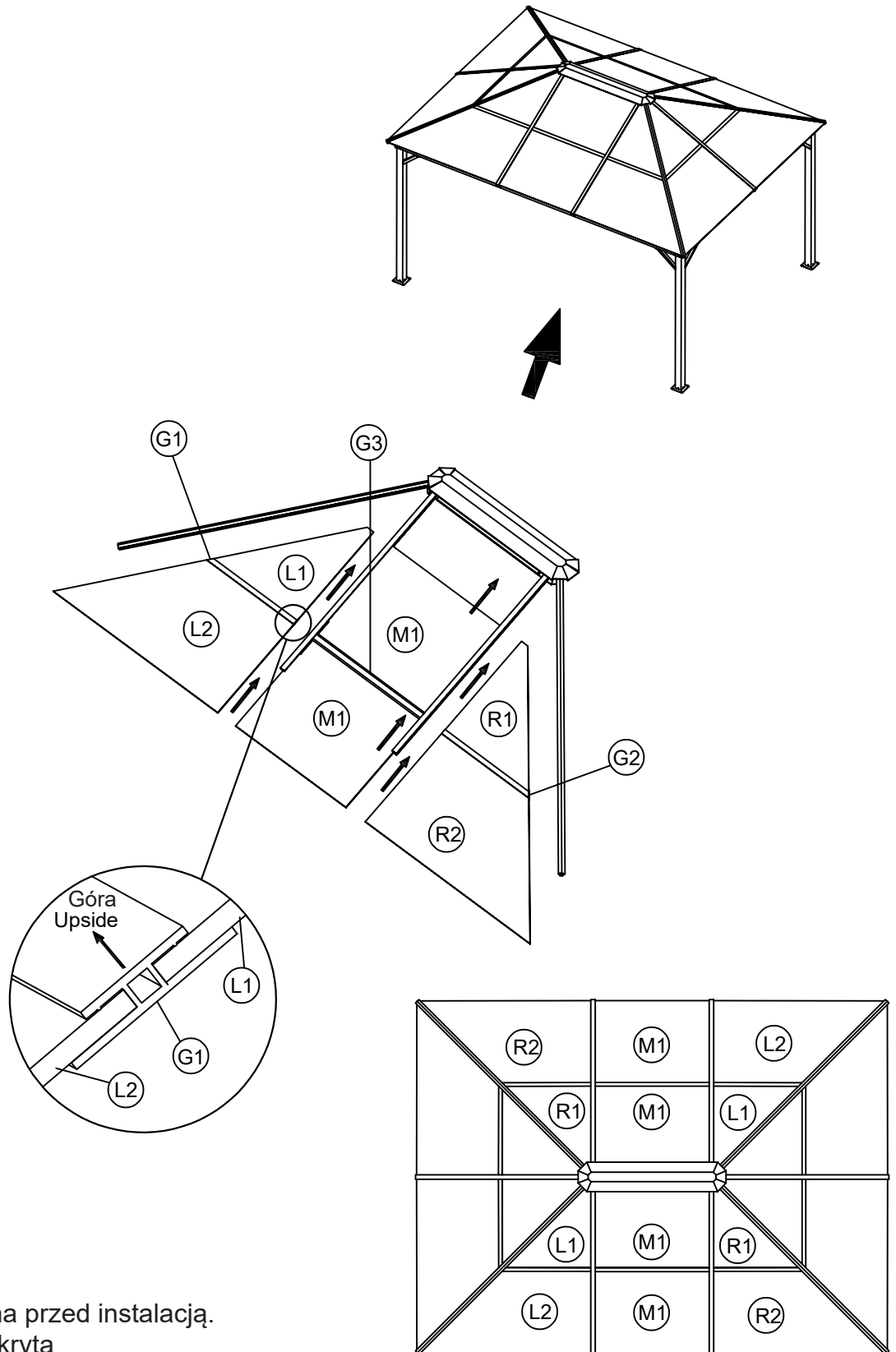
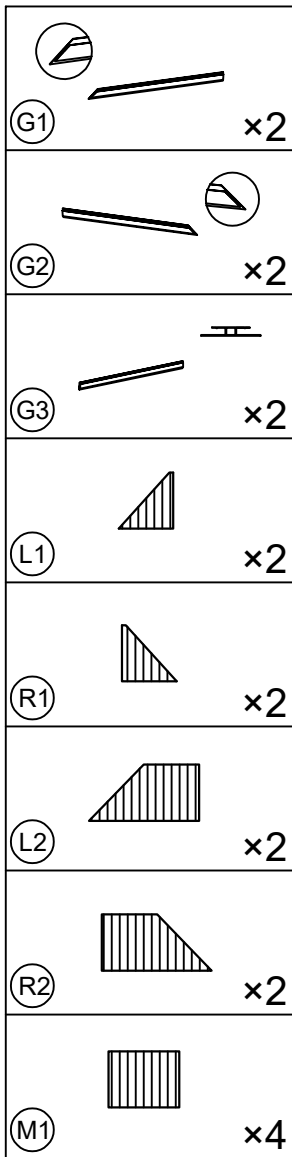









Uwaga:

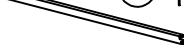

1. Zdejmij folie ochronną przed instalacją.
2. Montować stroną pokrytą **transparentną folią ochronną do góry.**

Notice:

1. Remove the protective film before installation.
2. The side covered with the **transparent protective film must face the sunlight!**

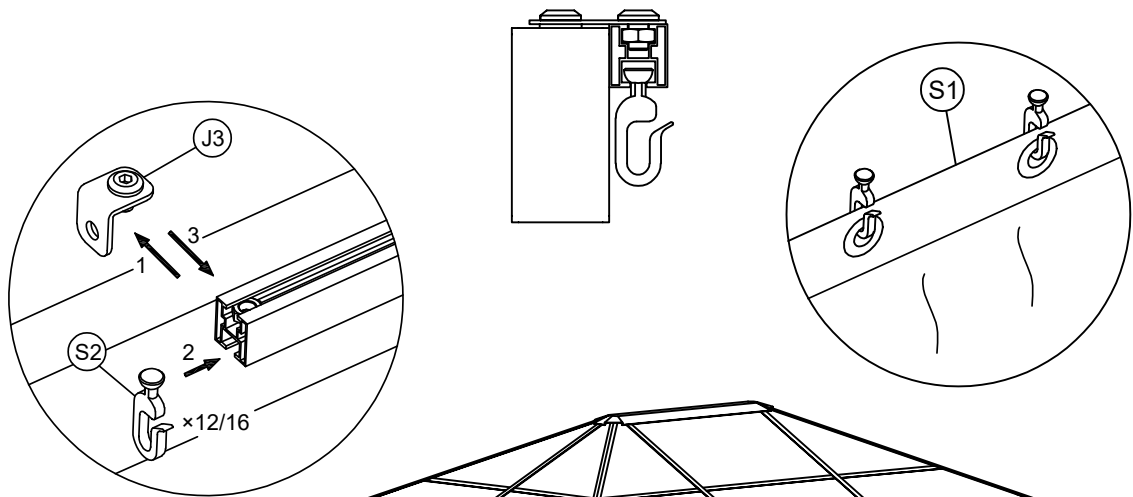
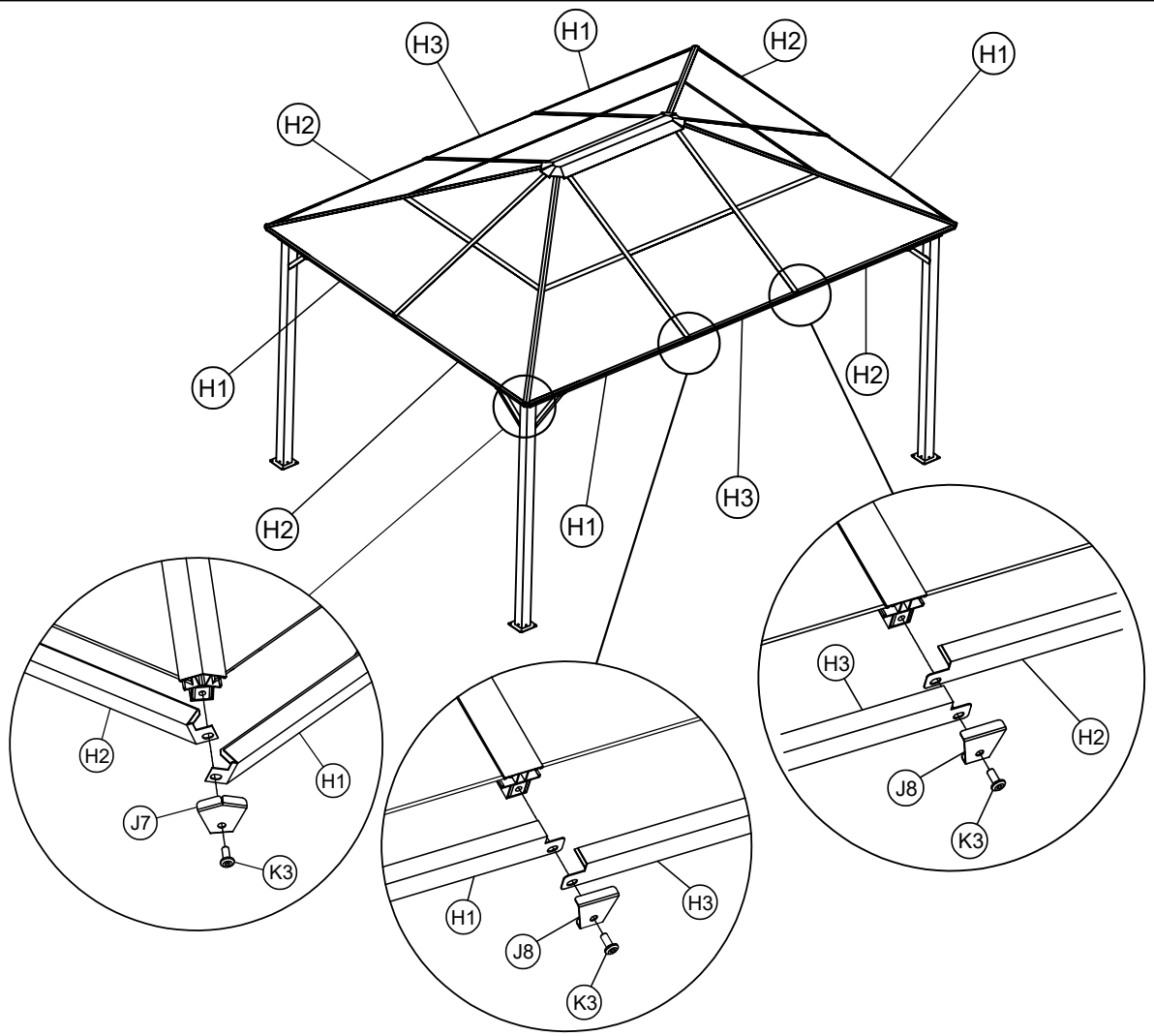
-   x4
-   x4
-   x2
-  x4
-  x6
- M6 x 15**
-  x10



- Sidewall**
-  x4
 -  x56

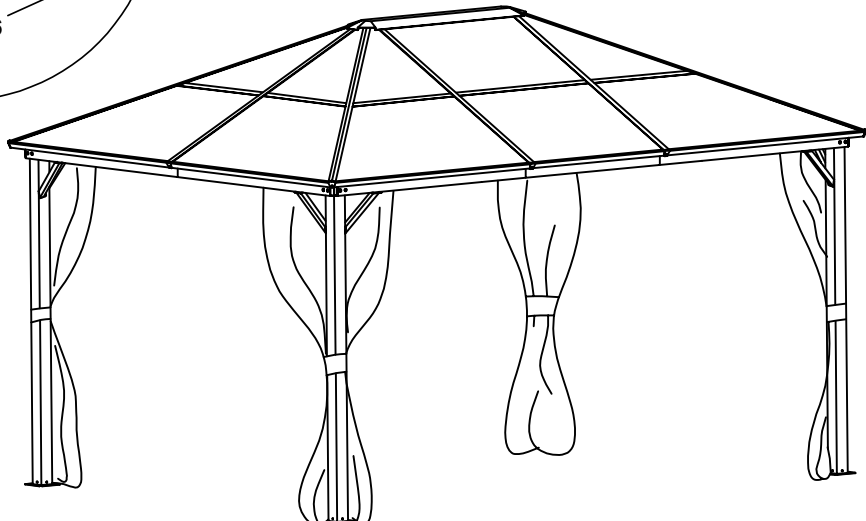

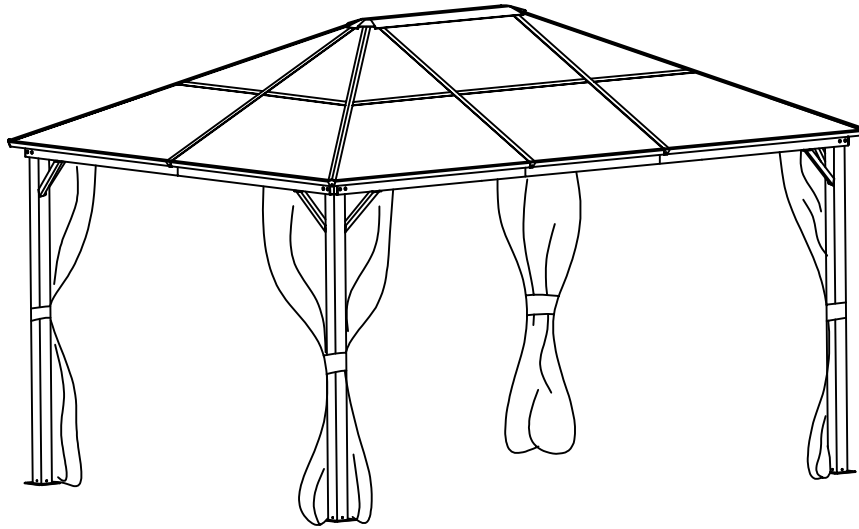

PL

INSTRUKCJA KONSERWACJI, CZYSZCZENIA I PRZECHOWYWANIA W OKRESIE ZIMOWYM

CZYSZCZENIE

Należy pamiętać, że tkanina zastosowana przy pawilonie ogrodowym jest niezwykle wrażliwa na wszelkie środki czyszczące. Do czyszczenia zabrudzeń powinniśmy wykorzystywać wodę w temperaturze pokojowej i miękką szczotkę. Po czyszczeniu materiał należy zostawić w suchym i wentylowanym miejscu, by samoistnie wyschnął. Produkt nie jest przeznaczony do prania w pralce, suszeniu suszarką. Latem powinniśmy pamiętać o usuwaniu liści z dachu.

KONSERWACJA

Najlepszym momentem na sprawdzenie stanu Pawilonu jest czas przed zimą. Chowając konstrukcję możemy dokładnie się przyjrzeć i sprawdzić, czy pojawiły się jakieś ubytki. Jeśli zauważymy ślady rdzy to powinniśmy jak najszybciej zlikwidować ją i pokryć specjalną farbą.

Raz w miesiącu należy sprawdzić czy:

- Konstrukcja stoi na płaskim gruncie,
- Kotwy nadal są przymocowane w ziemi,
- Żadna ze śrub nie uległa zniszczeniu,

Należy regularnie sprzątać zadaszenie pawilonu z liści i innych zanieczyszczeń.

ZIMA ORAZ ZŁE WARUNKI POGODOWE

W przypadku pogorszenia się pogody np. wystąpienia silnego, porywistego wiatru jak i nadejściu zimy niezbędne jest odpowiednie zabezpieczenie konstrukcji, by uniknąć jej zniszczenia. Pawilon ogrodowy powinniśmy złożyć i przechować w suchym miejscu. W ten sposób jego żywotność ulegnie wydłużeniu i produkt posłuży przez wiele sezonów. Produkt wymaga kotwienia w ziemi. Należy mieć na uwadze, że produkt nie jest przeznaczony do przytwierdzenia do podłoża na stałe - w przypadku wystąpienia niesprzyjających warunków pogodowych mogących wpłynąć negatywnie na produkt należy go złożyć i przechowywać w odpowiednim miejscu (wolnym od wilgoci, suchym).

EN

MAINTENANCE, CLEANING AND STORAGE IN THE WINTER SEASON - INSTRUCTIONS

CLEANING

Please note that the fabric used it is extremely sensitive near the garden pavilion for all cleaning products. We should clean dirt use water at room temperature and a soft brush. After cleaning, the material should be leave in a dry and ventilated place, to dry on its own. The product is not intended for washing in a washing machine and drying with a dryer. In summer, we should remember to remove leaves from the roof.

MAINTENANCE

The best time to check the condition of the Pavilion it's time before winter. We can hide the structure look carefully and see if any appear cavities. If we notice traces of rust, we should remove it as soon as possible and cover it with special paint.

Once a month, check whether:

- The structure stands on flat ground,
- The anchors are still attached in the ground,
- None of the screws were damaged,

The roof should be cleaned regularly pavilion from leaves and other debris.

WINTER AND BAD WEATHER CONDITIONS

In case the weather deteriorates e.g. occurrence of strong, gusty winds such as and the arrival of winter is necessary securing the structure to avoid its destruction. We should assemble the garden pavilion and store it in a dry place. Thus its service life will be extended and the product will last for a long time seasons. The product requires anchoring in the ground. Belongs bear in mind that the product is not intended for permanently attaching to the ground - in case of occurrence of unfavorable weather conditions that may negatively affect the product should be removed fold and store in a suitable place (moisture-free, dry).